

E5 Cam Latch

Zinc · L-handle · Hand operated · Fixed grip

Features

- Single hole install
- Multiple key codes
- NEMA 4 / IP65 achieved using supplied gasket

Product Performance

- Maximum static load: 330 N
- Mounting nut maximum tightening torque: 10 N.m
- Screw maximum tightening torque: 10 N.m

Material

- Zinc alloy, powder coated or chrome plated and steel, zinc plated

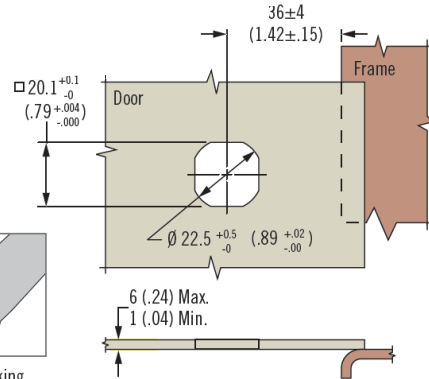
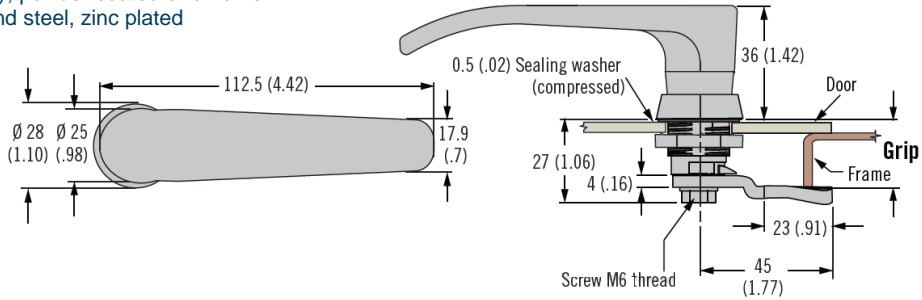

L Lock Style

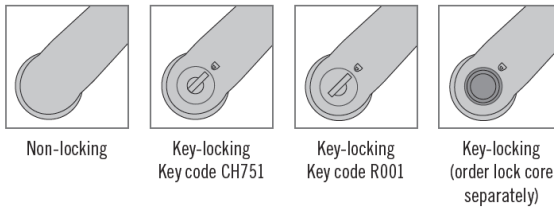

Latch Part Number
(no cam)

E5 - 9 - L F - UU1 - 1 K

F Finish

- 2 Bright chrome
- 5 Black powder coated

L Lock style

- 70 Non-locking (omit last two digits of part number)
- 71 Keyed CH751 (lock core finish matches handle finish)
- 72 Keyed R001 (stainless steel scalp shuttered)
- 73 Without lock core (omit last two digits of part number)
Order lock core separately

K Key options

- 0 No keys supplied (order separately)
- 3 1 Overmolded key supplied

Cam Part Number Table (order separately from latch)

Grip	Part Number	Grip	Part Number	Grip	Part Number	Grip	Part Number
4 (.16)	E5-6003	14 (.55)	E5-6008	24 (.94)	E5-6013	34 (1.34)	E5-6018
6 (.24)	E5-6004	16 (.63)	E5-6009	26 (1.02)	E5-6014	36 (1.42)	E5-6019
8 (.31)	E5-6005	18 (.71)	E5-6010	28 (1.10)	E5-6015	38 (1.50)	E5-6020
10 (.39)	E5-6006	20 (.79)	E5-6011	30 (1.18)	E5-6016	40 (1.57)	E5-6021
12 (.47)	E5-6007	22 (.87)	E5-6012	32 (1.25)	E5-6017	42 (1.65)	E5-6022